

KL20

Installation and operating instructions

TESA

ASSA ABLOY

Experience a safer
and more open world

SPECIAL NOTES

Please read carefully:

- Before installing the lock, familiarise yourself with the installation and operating instructions.
- The factory preset combination is 0-0-0-0.
- Your KL20 is supplied ready to fit to doors up to 22 mm ($\frac{7}{8}$ ") thick.
- Please refer to the dimensions on the reverse to select the correct back plate for the door thickness.

INSTALLATION GUIDE

The KL20 is designed to be fitted flush into a 27 mm x 83 mm ($1\frac{1}{16}$ " x $3\frac{1}{4}$ ") hole, either for a new install, or to replace an existing mechanical cam lock.

Contents (Default Supply)

- 1 KL20
- 2 Back Plate A with 4 x screws
- 3 Back Plate B with 4 x screws
- 4 Straight Cam x 1
- 5 Cam Fixing Screw x 1

Optional Fixing Pack

- 1 Back Plate C with 4 x screws
- 2 Straight Cam x 1
- 3 Cranked Cam x 2

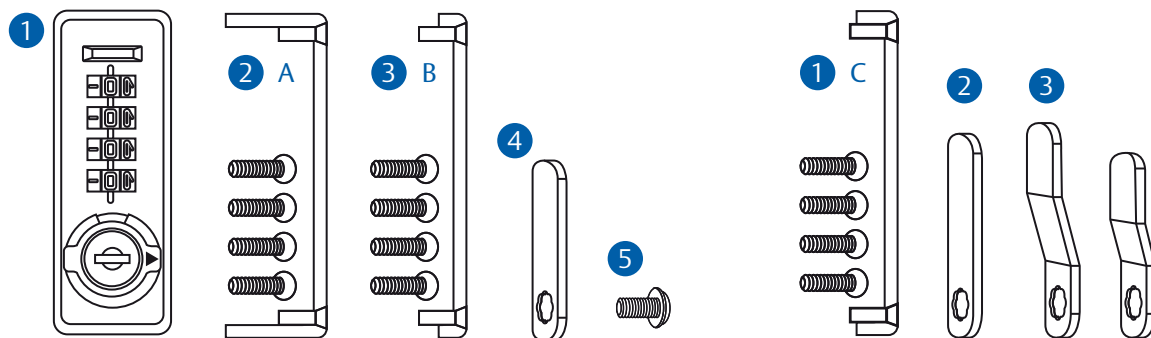

A/ Installing your KL20

N.B. Optional Fixing Pack (above) may be required.

- Step 1** If necessary, remove existing cam lock.
- Step 2** Mark a position at a suitable distance from the door edge, ensuring enough clearance for the cam to work.
- Step 3** Mark a rectangular guide 27 mm x 83 mm ($1\frac{1}{16}$ " x $3\frac{1}{4}$ ") to suit the chosen orientation.
- Step 4** Drill inside the four corners, then using a hacksaw or jigsaw, cut from the hole to hole to create the rectangle.
- Step 5** Hold the lock in place and secure with the correct back plate for the door thickness, using the 4 fixing screws supplied.
- Step 6** Fit cam and secure with cam fixing screw.
- Step 7** Now check the operation of the lock using the factory preset combination 0-0-0-0.
- Step 8** Change the code using the instructions overleaf.

CHANGING THE CODE

The factory preset combination is 0-0-0-0. The combination can be reset with the handle in the fully locked / unlocked position.

Note: Do not set your combination to 0-0-0-0.

The dials will auto-scramble to 0-0-0-0 when the handle is turned to prevent leaving your code exposed.

1. Turn the dials to the preset combination 0-0-0-0.
2. Slide the Reset Button to the reset position.
3. Set your new combination.
Note If the dials are loose, ensure the handle is fully turned.
4. Slide the Reset Button back to centre position. Make a note of your new combination prior to locking.

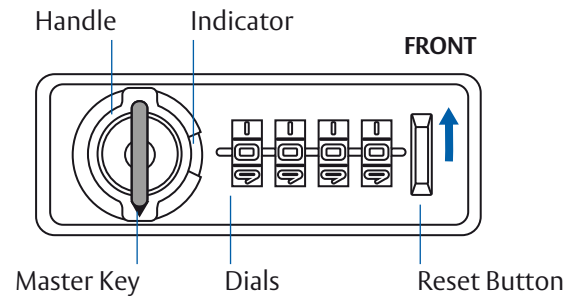
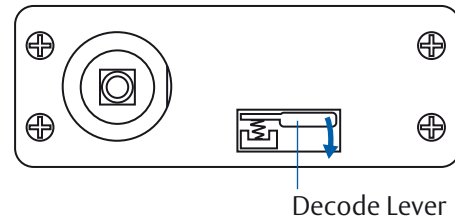

Fig.1 BACK



FINDING THE CODE

Note This function requires the Master Key (sold separately). This method should only be used to open the lock in an emergency, or when the User Code has been forgotten.

1. When the indicator is in the locked position, insert the Master Key and turn 180 degrees clockwise to open the door. Turn the Master Key 180 degrees counterclockwise and then remove the key.
2. With the door now open, you can access the back of the lock. Push and **hold** the Decode Lever towards the nearest edge of the lock (**Fig. 1**), and turn each dial towards the Decode Lever. You will feel a click as each code number is found, and the dial will stop turning. If the dial continues to turn, make sure you are turning the dials the correct way.
3. Release the Decode Lever when all four code numbers have been found. Make a note of the combination and ensure it unlocks the lock. You can now reset, or continue to use, the found combination.

DIMENSIONS

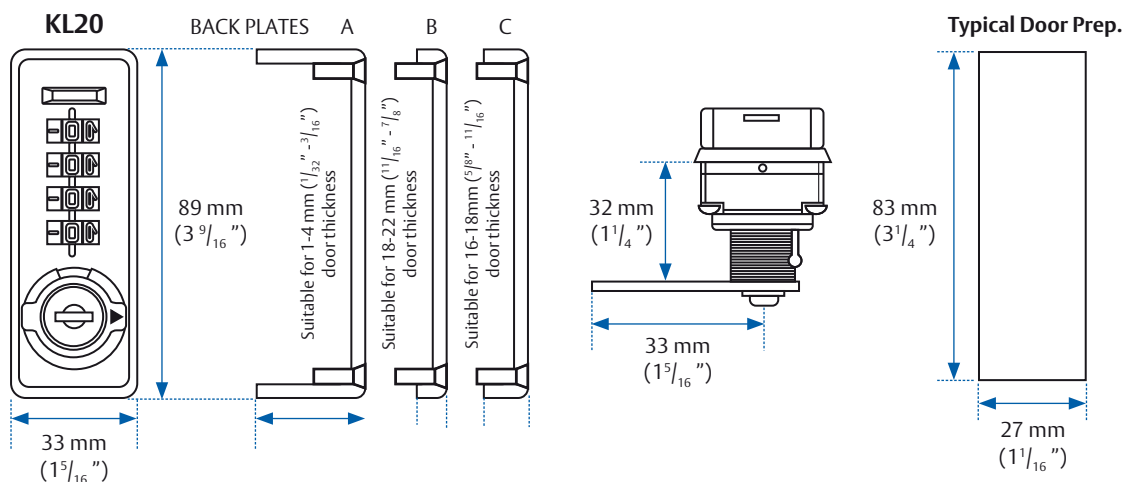

TESA ASSA ABLOY
Talleres de Escoriaza, S.A.U.
Barrio Ventas, 35
E-20305 Irun · Guipúzcoa
Tel.: +34 943 669 100
Fax: +34 943 633 221
www.tesa.es

Talleres de Escoriaza, S.A.U.
OEM Division
Sierra de Segura, 15
28830 San Fernando de Henares
Madrid - Spain
Tel. 91 678 55 09
Fax. 91 678 55 19
orders.oem@tesa.es



ASSA ABLOY

Experience a safer
and more open world